

HOEKLIJST

2962.70



2962.70.

Form C

Km 8 x 9,6 tief DIN 74

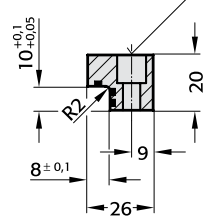

Form A

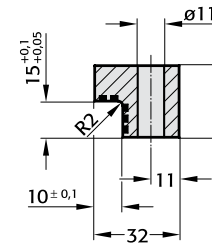

Form B

Km 10 x 25 tief DIN 74

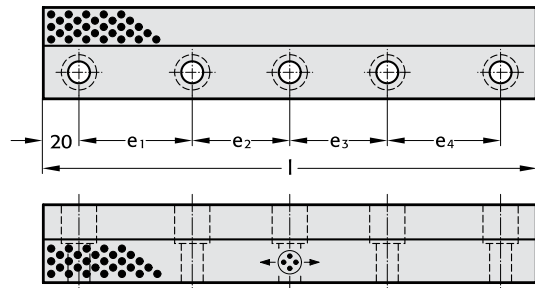
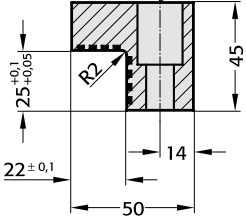

Werkstoff:

Bronze mit Festschmierstoff, wartungsarm.

Hinweis:

Lieferung ohne Schrauben.



Gleitrichtung Festschmierstoff-Einsätze (Ausschnitt)

Bestell-Beispiel:

Winkelleiste	=	2962.70.
Form A	=	032.
l = 150 mm	=	150
Bestell-Nummer	=	2962.70.032.150

2962.70.

Bestell-Nr.	Form	l	e ₁	e ₂	e ₃	e ₄	Anzahl Bohrungen
2962.70.026.100	C	100	60	-	-	-	2
150		150	55	55	-	-	3
200		200	55	50	55	-	4
2962.70.032.100	A	100	60	-	-	-	2
150		150	55	55	-	-	3
200		200	55	50	55	-	4
250		250	70	70	70	-	4
2962.70.050.200	B	200	55	50	55	-	4
250		250	70	70	70	-	4
300		300	65	65	65	65	5
350		350	80	75	75	80	5

HOEKLIJST

2962.73



2962.73.

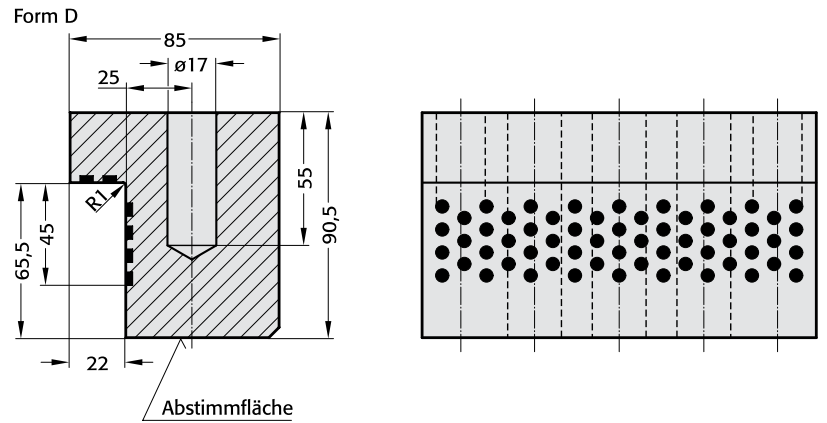
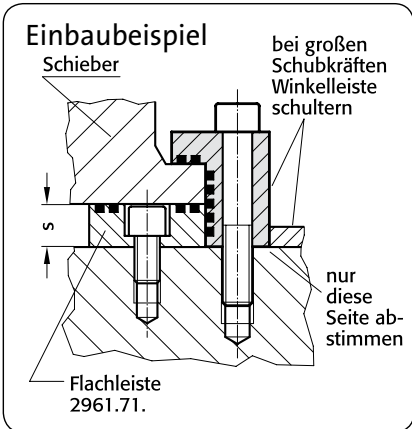
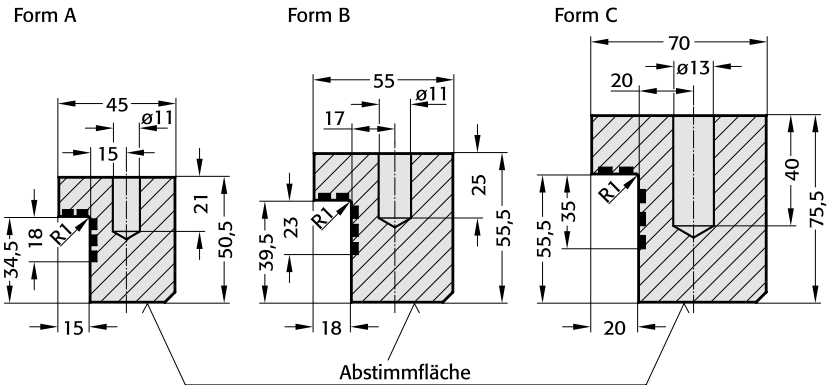

Werkstoff:
Bronze mit Festschmierstoff, wartungsarm.

Hinweis:
Lieferung ohne Schrauben.

Befestigung:
Zylinderschrauben DIN EN ISO 4762 und Zylinderstifte DIN 7979 verwenden.

Bestell-Beispiel:
Winkelleiste = 2962.73.
Form A = 045.
l = 100 mm = 100
Bestell-Nummer = 2962.70.045.100

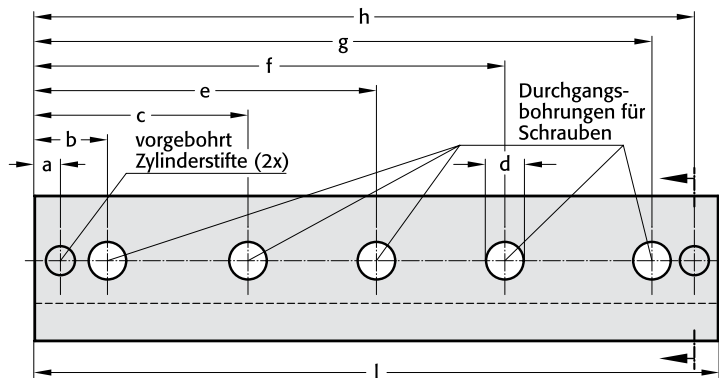

2962.73.											Zylinderschrauben		Zylinderstifte		s
Bestell-Nr.	Form	l	a	b	c	e	f	g	h	d	Größe	Anzahl	Größe	Anzahl	
2962.73.045.100	A	100	10	27,5	-	-	-	72,5	90	13	M12 x 80	2	10 x 60	2	16
2962.73.045.160		160	-	-	-	-	-	132,5	150	-	-	-	-	-	-
2962.73.055.100	B	100	-	-	-	-	-	72,5	90	-	-	-	-	-	-
2962.73.055.160		160	-	-	-	-	-	132,5	150	-	-	-	-	-	-
2962.73.070.160	C	160	12,5	35	-	-	-	125	147,5	17	M16 x 100	-	12 x 70	-	20
2962.73.070.200		200	-	-	-	-	-	165	187,5	-	-	-	-	-	-
2962.73.070.250		250	-	-	-	125	-	215	237,5	-	-	3	-	-	-
2962.73.070.400		400	-	-	125	200	275	365	387,5	-	-	5	-	-	-
2962.73.085.160	D	160	15	42,5	-	-	-	117,5	145	21	M20 x 120	2	16 x 70	-	-
2962.73.085.200		200	-	-	-	-	-	157,5	185	-	-	-	-	-	-
2962.73.085.250		250	-	-	-	125	-	207,5	235	-	-	3	-	-	-
2962.73.085.400		400	-	-	125	200	275	357,5	385	-	-	5	-	-	-

HOEKLIJST

2962.82



2962.82.

Form B

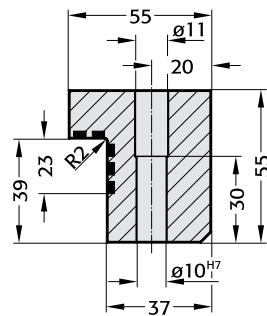

Form C

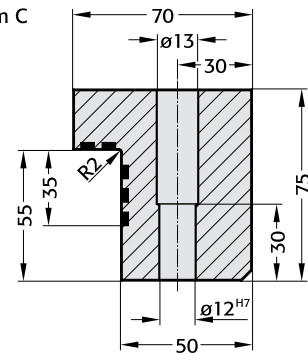

Form D

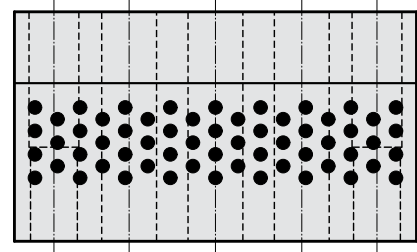
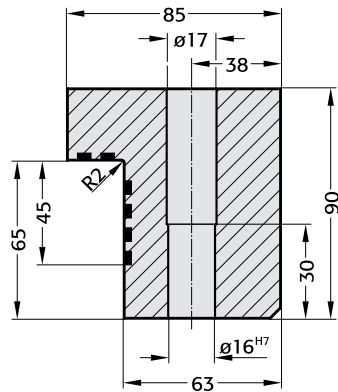

Einbaubeispiel:

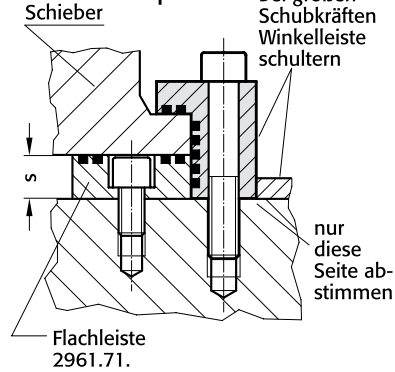

Werkstoff:

Bronze mit Festschmierstoff, wartungsarm.

Hinweis:

Lieferung ohne Schrauben und Stifte.

Befestigung:

Zylinderschrauben DIN EN ISO 4762 und Zylinderstifte DIN 7979 verwenden.

Bestell-Beispiel:

Winkelleiste	=	2962.82.
Form B	=	055.
l = 100 mm	=	100
Bestell-Nummer	=	2962.82.055.100

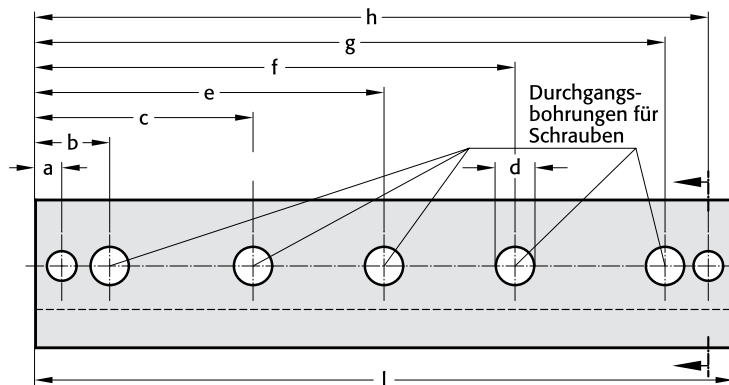

2962.82.

Bestell-Nummer	Form	l	a	b	c	e	f	g	h	d	Zylinderschr.		Zylinderstifte		s
											Größe	Anzahl	Größe	Anzahl	
2962.82.055.100	B	100	10	27,5	-	-	-	72,5	90	13,5	M12 × 80	2	10 × 60	2	16
160		160						132,5	150						
2962.82.070.160	C	160	12,5	35	-	-	-	125	147,5	17,5	M16 × 100		12 × 70		20
200		200						165	187,5						
250		250				125	200	215	237,5			3			
400		400					275	365	387,5			5			
2962.82.085.160	D	160	15	42,5	-	-	-	117,5	145	22	M20 × 120	2	16 × 70		
200		200						157,5	185						
250		250				125		207,5	235			3			
400		400					275	357,5	385			5			

HOEKLIJST

2962.71

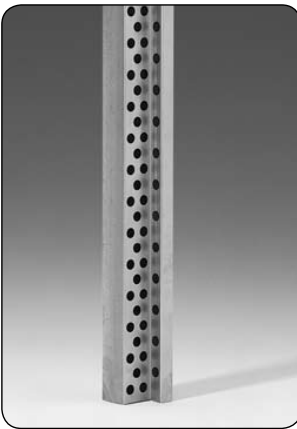

2962.71.020.012.

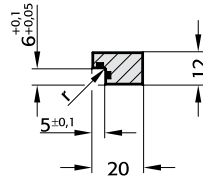

2962.71.025.015.

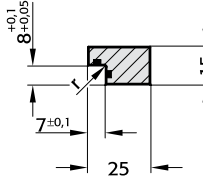

2962.71.030.020.

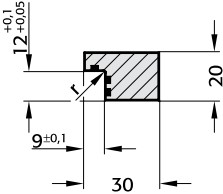

2962.71.032.030.

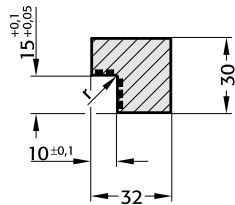

2962.71.035.035.

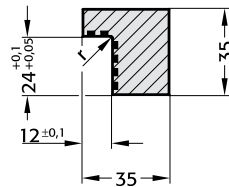

2962.71.050.045.

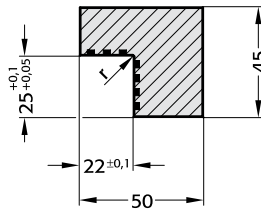

2962.71.050.050.

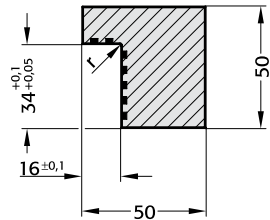

Werkstoff:

Bronze mit Festschmierstoff,
wartungsarm.

2962.71.

Bestell-Nr.	Länge	
	305	1005
2962.71.020.012.	●	
025.015.	●	
030.020.	●	
032.030.		●
035.035.	●	●
050.045.	●	●
050.050.	●	●

Bestell-Beispiel:

Winkelleiste	=	2962.71.
Breite = 32 mm	=	032.
Höhe = 30 mm	=	030.
Länge = 605 mm	=	0605
Bestell-Nummer	=	2962.71.032.030.0605

HOEKLIJST

2962.72

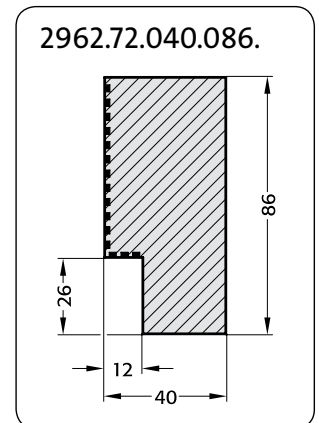
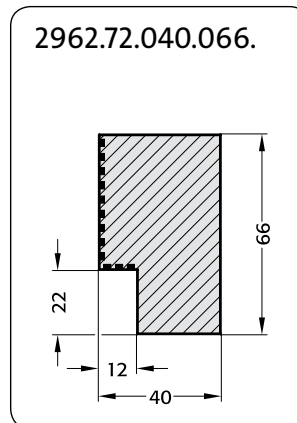
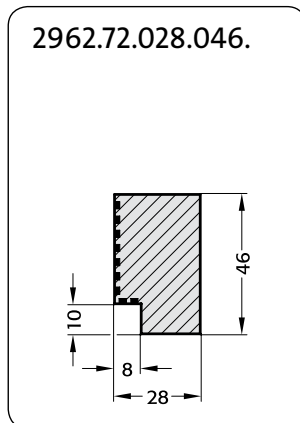
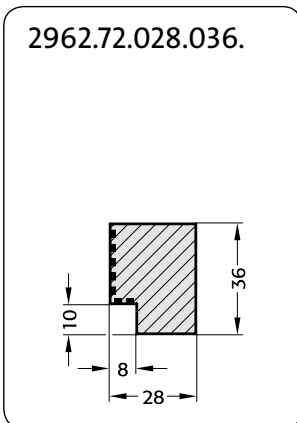
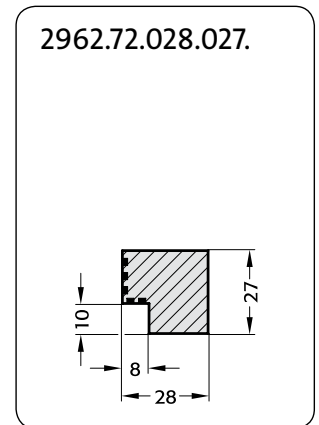
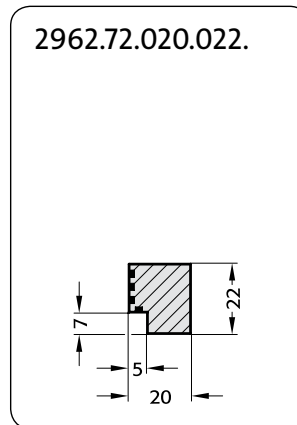
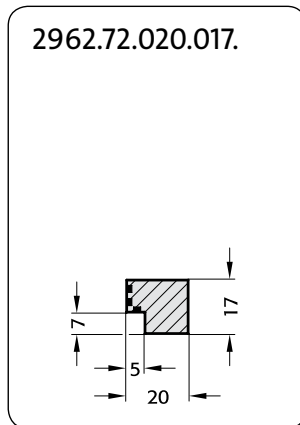
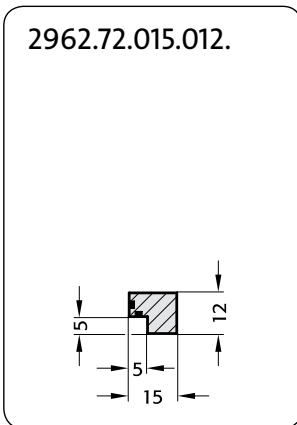
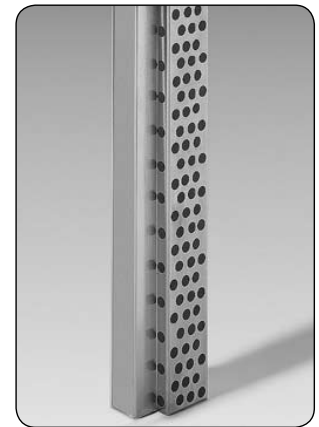
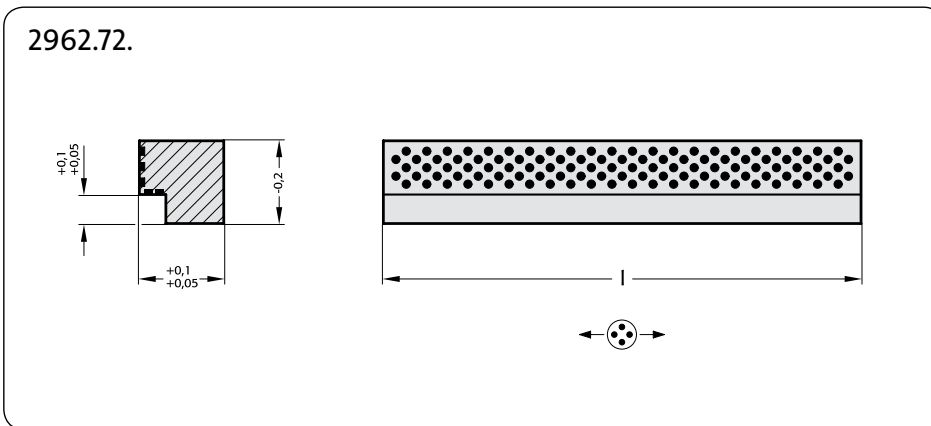

2962.72.

Bestell-Nummer	205	320	605
2962.72.015.012.	•		
020.017.	•	•	
020.022.	•	•	
028.027.	•	•	•
028.036.	•	•	•
028.046.	•	•	•
040.066.	•	•	•
040.086.	•	•	•

Werkstoff:
Bronze mit Festschmierstoff, wartungsarm.

← ⊙ → Gleitrichtung Festschmierstoff-Einsätze (Ausschnitt)

Bestell-Beispiel:
Winkleiste = 2962.72.020.022.
l = 205 mm = 0205
Bestell-Nummer = 2962.72.020.022.0205

HOEKLIJST

2962.81

2962.81.

Form A

Form B

Form C

Form D

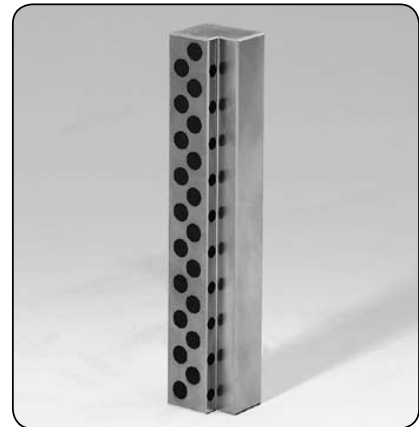
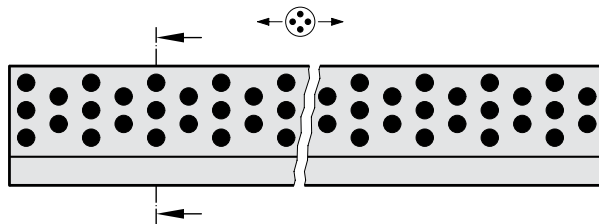
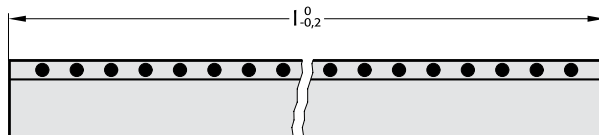
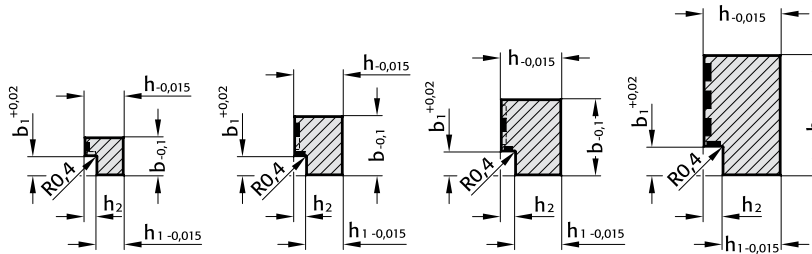

Werkstoff:

Bronze mit Festschmierstoff, wartungsarm.

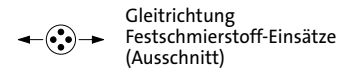

2962.81.

Bestell-Nr.	Form	h	b	l	h ₁	h ₂	b ₁
2962.81.016.115.040	A	16	11,5	40	12	4	6
050	A			50			
063	A			63			
080	A			80			
2962.81.016.155.050	A	16	15,5	50	11	5	8
063	A			63			
080	A			80			
100	A			100			
2962.81.020.195.063	B	20	19,5	63	15	5	8
080	B			80			
100	B			100			
125	B			125			
2962.81.020.245.080	B	20	24,5	80	15	5	8
100	B			100			
125	B			125			
160	B			160			
2962.81.025.315.100	C	25	31,5	100	19	6	10
125	C			125			
160	C			160			
200	C			200			
2962.81.025.395.125	D	25	39,5	125	19	6	10
160	D			160			
200	D			200			
250	D			250			
2962.81.032.495.160	D	32	49,5	160	24	8	12
200	D			200			
250	D			250			
315	D			315			

Bestell-Beispiel:

Winkelleiste = 2962.81.
 h = 16 mm = 016.
 b = 11,5 mm = 115.
 l = 40 mm = 040
 Bestell-Nr. = 2962.81.016.115.040

T-LIJST

2964.77/78

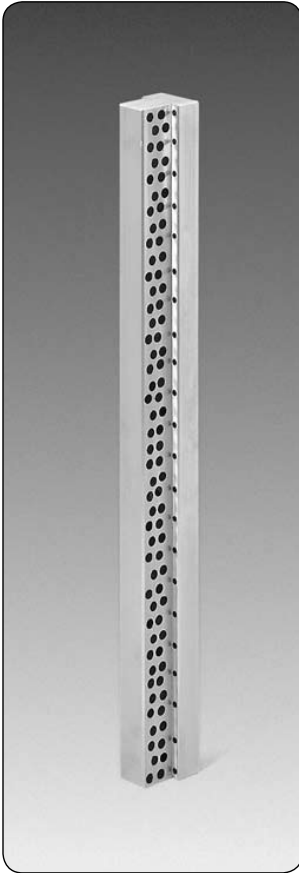

2964.77.

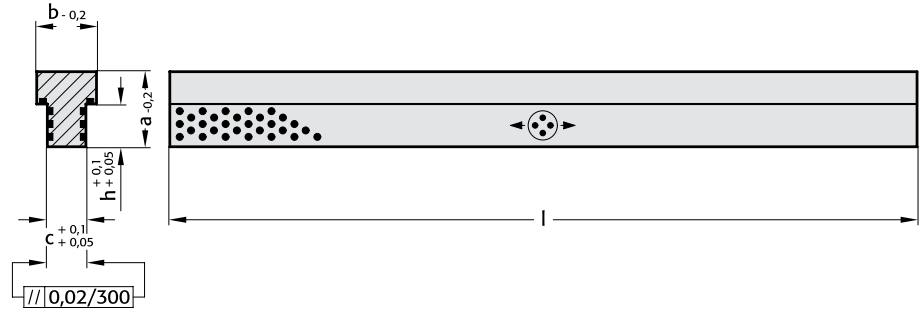

Werkstoff:

Bronze mit Festschmierstoff, wartungsarm.



Gleitrichtung
Festschmierstoff-Einsätze
(Ausschnitt)

2964.77.

Bestell-Nummer	a	b	c	h	l
2964.77.012.018.0350	12	18	8	5	350
025.022.0350	25	22	12	15	350
035.028.0350	35	28	18	20	350

Bestell-Beispiel:

T-Leiste = 2964.77.
 a = 12 mm = 012.
 b = 18 mm = 018.
 l = 350 mm = 0350
 Bestell-Nummer = 2964.77.012.018.0350

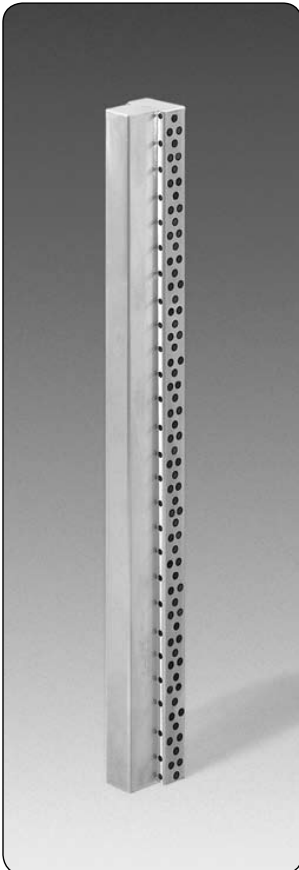

2964.78.

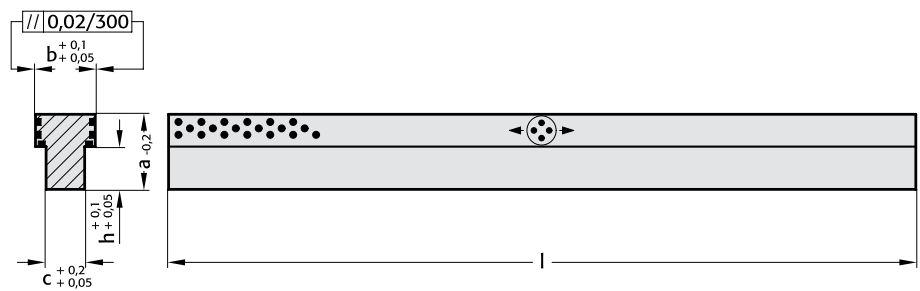

Werkstoff:

Bronze mit Festschmierstoff, wartungsarm.



Gleitrichtung
Festschmierstoff-Einsätze
(Ausschnitt)

2964.78.

Bestell-Nummer	a	b	c	h	l
2964.78.012.018.0350	12	18	8	5	350
025.022.0350	25	22	12	15	350
035.028.0350	35	28	18	20	350

Bestell-Beispiel:

T-Leiste = 2964.78.
 a = 12 mm = 012.
 b = 18 mm = 018.
 l = 350 mm = 0350
 Bestell-Nummer = 2964.78.012.018.0350

LARDON DE FROTTEMENT ANGULAIRE

2962.83

2962.83.

Form B

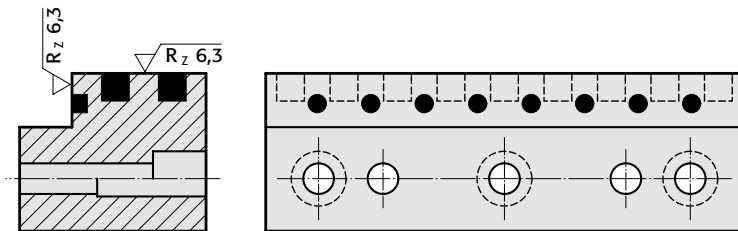

Form A

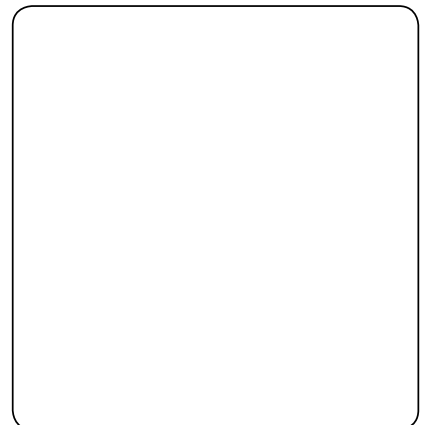
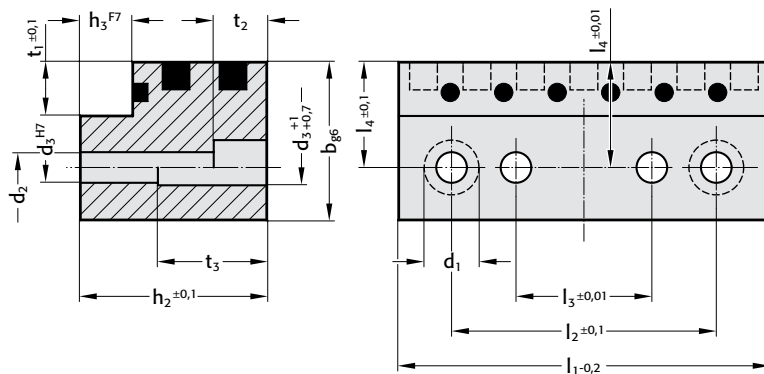

2962.83.

Bestell-Nr.	Form	b	h1	l1	l2	l3	l4	d1	d2	d3	t1	t2	t3	h2	h3	Anzahl Bohrungen
2962.83.016.012.050	A	16	12	50	34	14	9,5	10	5,5	5	5	5,7	-	11	4	2
016.012.071	A			71	55	35										2
016.012.090	B			90	74	54										3
2962.83.020.020.080	A	20	20	80	64	40	12	11	6,6	6	5	6,8	9,5	19	5	2
020.020.100	A			100	84	60										2
020.020.125	B			125	109	85										3
2962.83.025.032.100	A	25	32	100	80	50	15,5	15	9	8	6	9	19	31	6	2
025.032.125	A			125	105	75										2
025.032.160	B			160	140	110										3
2962.83.030.050.125	A	30	50	125	95	55	18	18	11	10	7	11	34	49	8	2
030.050.160	A			160	130	90										2
030.050.200	B			200	170	130										3

Bestell-Beispiel:

Winkelleiste	=	2962.83.
b = 16 mm	=	016.
h1 = 12 mm	=	012.
l1 = 50 mm	=	050
Bestell-Nummer	=	2962.83.016.012.050